

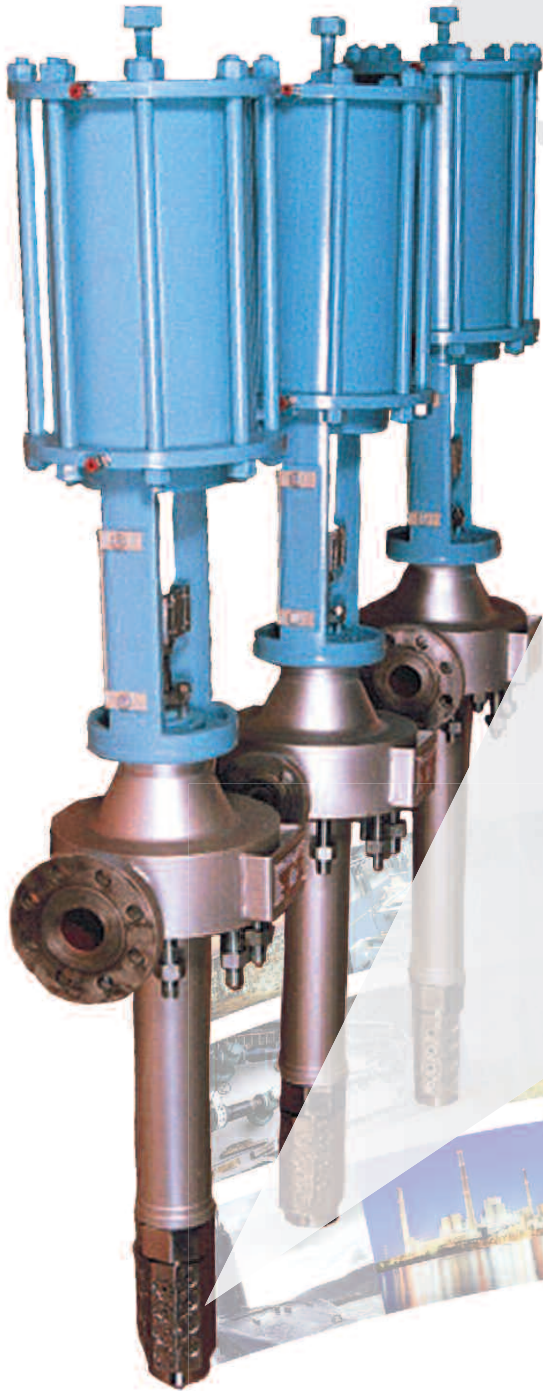

DESUPERHEATER SOLUTIONS



*Lancer
Variable Nozzle
Assembly*



*Multi-Nozzle Lancer
Desuperheater*

Broad Portfolio of Desuperheating Solutions

Circor offers various types of desuperheaters to meet customers' temperature control needs. CIRCOR's portfolio of desuperheating products includes probe style, venturi style as well as spray ring style desuperheaters. We can offer a customized solution no matter what your desuperheating need is.

Below are the types of desuperheaters Circor offers:

Probe Style...

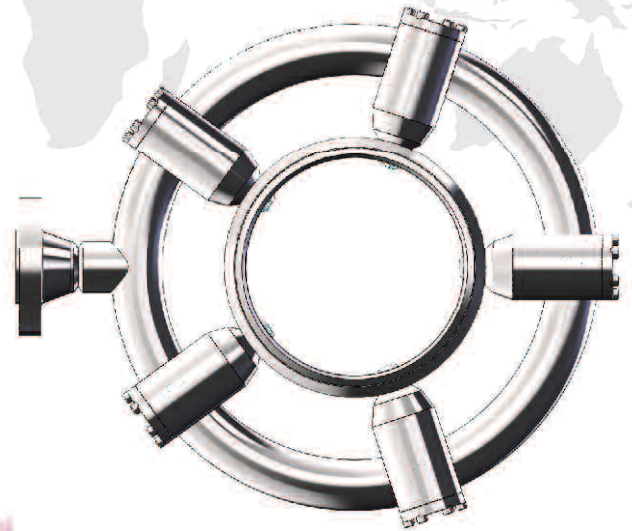
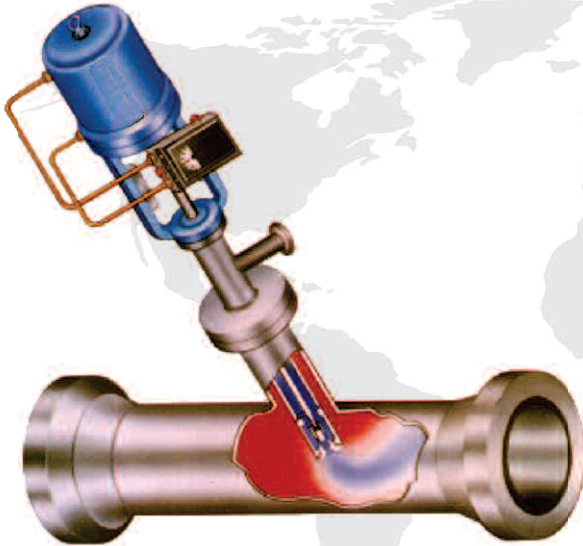

Spray Ring Style ...

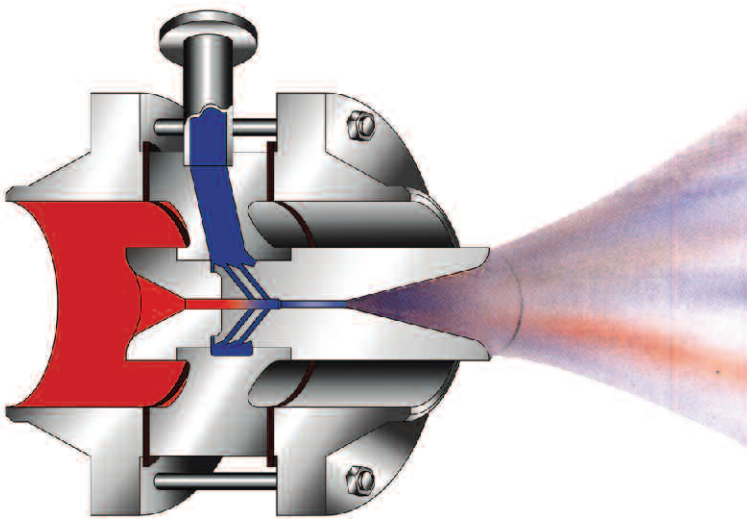

Venturi Style...

Desuperheaters - Purpose...

Desuperheaters are a critical component used in the management of steam from power generation sources to industrial uses of steam. Desuperheating, sometimes called attemperation, is the reduction of temperature in a steam line through the direct contact and evaporating of water within the steam flowstream. The principle function of any desuperheater is to accelerate the phenomena of absorption of the spray water by the steam, so that steady conditions of steam temperature are reached within a short distance from the outlet.

The overall purpose, therefore, of a desuperheater is to provide for effective heat transfer between steam and water. Effective desuperheater design and application ensures that costly problems, including extended startup and shutdown times, reduced process efficiency, and general wear of downstream piping and equipment are avoided.



CIRCOR lancer desuperheater installed at power plant

Desuperheaters - Essential Design Characteristics

Temperature Control:

- Fast response to change in steam flow and temperature
- Accurate steam temperature control
- Ability to attemperate to near steam saturation temperature

Turndown/Rangeability:

- High Ratio of maximum to minimum controllable flow
- Excellent temperature control over the full range of flow

Prevent Overspray or Water Accumulation:

- Prevent excess water from being injected into flowstream
- Avoid thermal shock to steam pipe.

Eliminate Water Droplet Impact:

- Minimize water droplet size - Good atomization
- Ensure attemperation spray does not impact pipe wall

STYLE	PIPE SIZE		WATER FLANGE SIZE		CONFIGURATIONS		
	Model	Inch	mm	Inch	mm	Description of Design	
PROBE (Fixed/Variable Nozzle)	Lancer MUL3	3	80	1, 1½, 2	25, 40, 50	Turndown: 50:1 (> consult factory) Max Water %: 20% (> consult factory) Velocity: 8m/sec (Carbon Steel) 100 m/sec (Chrome Moly)	<ul style="list-style-type: none"> - Fabricated construction - Plug control of flow through multiple nozzles; multi-stage trim Actuator: Pneumatic Piston optional: multi-spring, electrical Control characteristic: Linear, modified linear
	Lancer MUL4	4	100				
SPRAY-RING		10" to 40"	250 to 1000	½ to 3	15 to 80	Turndown: 20:1 Water % Range: 25% - 45% Min Velocity: 15m/sec	<ul style="list-style-type: none"> - Multiple nozzle around inside diameter of pipe - Fixed orifice as well as spring-loaded nozzles - Optional liner
VENTURI	SINGLE	2	50	½ - 2	15 - 20	Turndown: 6:1 (Steam assist available with 40:1) Max Water %: 20% (> consult factory) Min Velocity: 10m/sec	<ul style="list-style-type: none"> - De Laval Nozzle with fixed orifice - Available to ANSI 2500 Class - 6:1 Rangeability
		3	80				
	DOUBLE	4	100	½ - 2	15 - 20	Turndown: 12:1 (Steam assist available with 40:1) Max Water %: 20% (> consult factory) Min Velocity: 10m/sec (consult factory)	<ul style="list-style-type: none"> - De Laval Nozzle with fixed orifice - Secondary body venturi improves performance - 12:1 Rangeability
		6	150				
INLINE	8	200	½ - 3	15 - 75	Turndown: 6:1 (Steam assist available with 40:1) Max Water %: 20% (> consult factory) Min Velocity: 10m/sec	<ul style="list-style-type: none"> - Fabricated construction - Body insert venture type vena contracta - Sized for pipe diameters to 40" 	
	10	250					
	12	300					
	14	350					
	16	400					
	18	450					
	24+	600+					
MINI	<2 2	< 50 50	<1, 1	<25, 25	Turndown: 6:1 Max Water %: 20% (> consult factory) Min Velocity: 10 mtr/sec	<ul style="list-style-type: none"> - Sized for pipe diameters to 2" - No moving parts - Venturi with sharp edge of steam entry 	

Lancer Probe Style Desuperheater

A Lancer desuperheater is a variable nozzle probe style desuperheater. It offers accurate temperature control without the need for a separate spray water valve. Sliding stem design with integral actuator enables precise metering of water in response to changing steam flow and temperature. Compact design allows for mounting in space constrained situations. The Lancer probe style is suitable for wide range of desuperheating applications in large power plants, cogeneration facilities, combined heat and power plants as well as chemical/process plants.

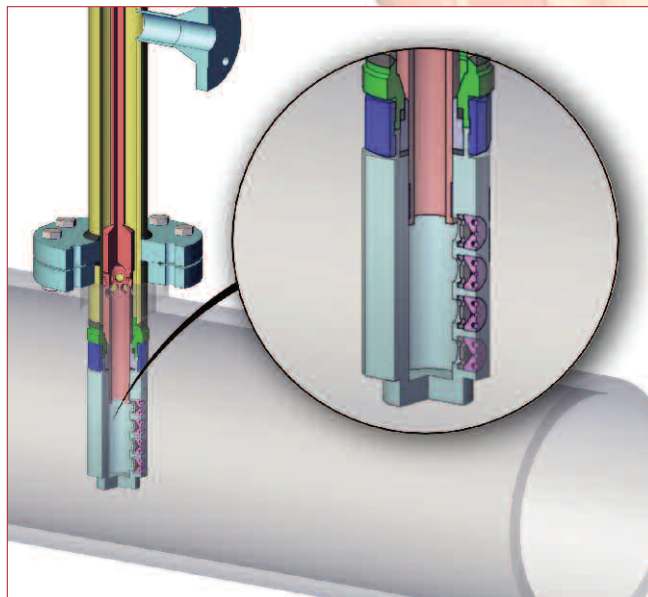

Lancer (MUL 3)

Style	Product Feature	Benefit
Probe	Unique nozzle design	Results in hollow cone spray that enables good water absorption
	Heavy Duty Construction	Long life
	Double Stem Guiding & Oversized Stem	Long life
	Integral Piston actuator	Separate spray water valve not needed
	Multiple nozzles of varying Cv	Accurate temperature control
	High Turndown	Allows for large variation in steam flow
	Compact design	Good for space constrained situations

Venturi Style Desuperheater

CIRCOR offers various types of Venturi Style desuperheaters to meet customers' needs. The biggest benefits of venturi style desuperheaters are low cost and lack of moving parts. Especially suited for cogeneration and combined heat and power plants, venturi style desuperheaters offer multiple desuperheating choices. A wide range of choices and custom engineering of 'Laval Jet' nozzle enable tailored fitting of desuperheating solution .

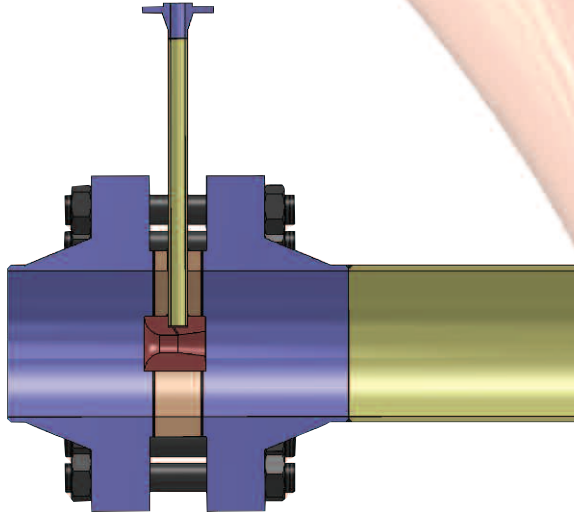

Single Venturi

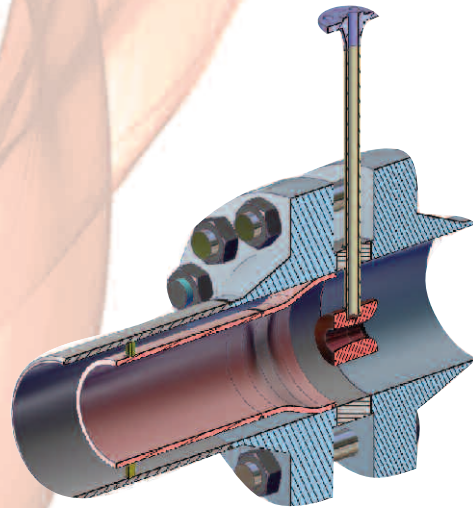

Double Venturi

Style	Product Feature	Benefit
Venturi	Laval Jet Nozzle	Superior water mixing due to increased turbulence
	Simple Construction	Low cost
	No moving parts	Low maintenance
	Steam assist option available	Allows desuperheating in low steam velocity situations

Spray Ring Style Desuperheater

The Spray Ring style desuperheater is a de facto standard in HP and LP Turbine bypass applications. CIRCOR offers a robust design to meet demanding needs of these applications in the power industry.

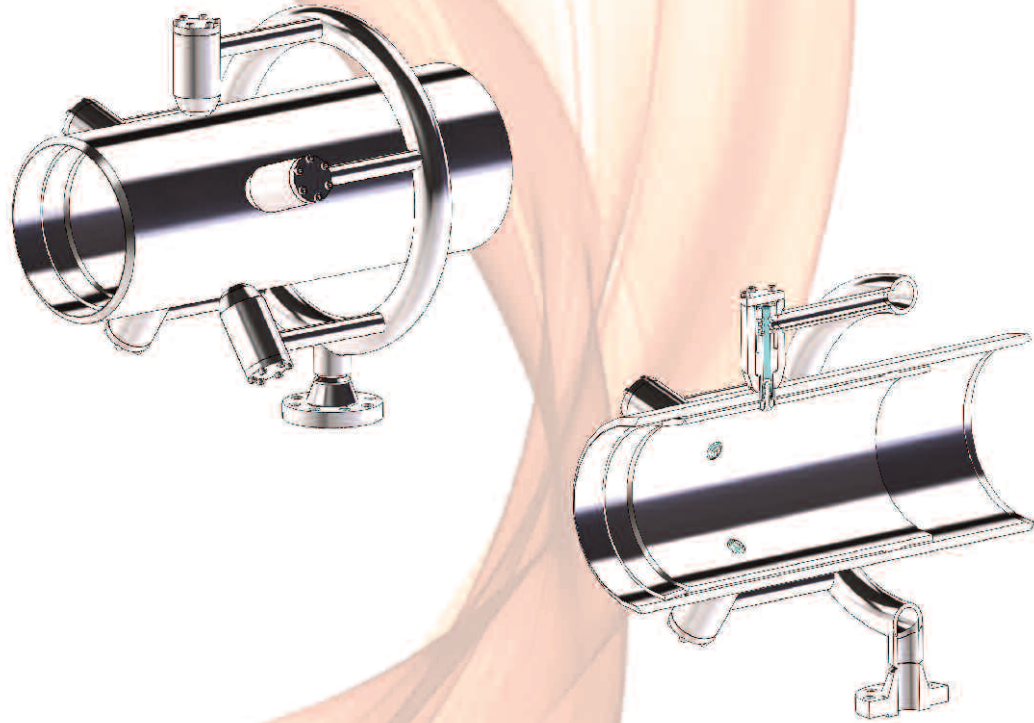

Style	Product Feature	Benefit
Spray Ring Style	Multiple nozzles around large pipe	Large water quantity allows for desuperheating of large quantity of steam during turbine trip
	Spring loaded nozzle option	No water dripping and leakage
	F91/F22 pipe/liner material	Meets the requirement of high steam temperature and pressure
	Steam assist option available	Allows desuperheating capability where steam velocity is low
	Five nozzle sizes	Ability to meet wide range of operating conditions
	Fabricated construction	Allows for custom fit solutions



...IN POWER...

CIRCOR International Inc. (NYSE: CIR) is a global enterprise comprised of market leading brands that collectively offer a broad range of flow control solutions. Our highly engineered solutions for power generation are marketed under the well known brand names of Leslie Controls, RTK and Pibiviesse control valves, on-off valves and associated actuation and instrumentation. Key to our growth has been – and will always be – our unequalled ability to optimally match technology to customer needs.

Customers consistently choose to partner with us because we are:

INNOVATIVE • leveraging technology to provide economic solutions

RESPONSIVE • exhibiting passion, speed and agility

CUSTOMER FOCUSED • driving quality, reliability and continuous improvement



Accelerating Growth

of the world's power infrastructure



Leslie Controls, Inc.
12501 Telecom Drive
Tampa, Florida 33637-0906
USA
Phone: 800.439.4485
Fax: 813.977.0174
www.lesliecontrols.com
sales@lesliecontrols.com



Regeltechnik Kornwestheim GmbH
Max-Planck-Str. 3
70806 Kornwestheim / Germany
Phone +49 7154 1314.0
Fax +49 7154 1314.333
www.rtk.de
info@rtk.de



Pibiviesse S.R.L.
Via Bergamina, 24
20014 Nerviano (Milan)
Italy
Phone: 39.0331.408711
Fax: 39.0331.408802
www.pibiviesse.it
info@pibiviesse.com



Circor Flow Technologies India Private Limited
Cowcoody Chambers - 1st Floor
234-A Race Course Road
Coimbatore 641018
Tamilnadu State, India
Phone: +91 422 4201600
infoCircorFlow@circor.com

For company structure and parent company questions: infoCircorFlow@circor.com

For more more information, contact your local Circor authorized representative: